

Commonwealth of Pennsylvania  
Department of Transportation

**SPECIFICATION FOR STAINLESS STEEL BAND AND ACCESSORIES**

August 30, 1995

**DESCRIPTION**

This material is for use in securing highway signs to poles, sign posts, sign structures, cables and performing other obvious clamping functions. In this system, using the band, band tool, band buckles and band brackets, a clamp may be formed to wrap around poles, sign posts, or any clampable object. All items shall work as components of a system.

**2. REQUIREMENTS**

2.1 **Stainless Steel Bands.** The band shall be type 201 stainless steel 3/4" width, .030" thickness and 100 ft. coil length. All bands shall be packaged (100 ft. per roll) in a box.

2.2 **Stainless Steel Buckle.** The band buckle shall be of ear-lock design, Type 201 stainless steel, 3/4" width. The buckle shall be designed to accommodate single and double wrap clamps. Buckles are to be packaged 100 each per box.

2.3 **Stainless Steel Bracket.** Type 201 stainless steel, .075" thick 1-bolt straight leg type. Hex head bolts, with metal and fiber washer, require no nuts and are fully threaded to solidly anchor signs. Brackets are to be packaged 50 each per box.

2.4 **Band Tool.** A drop forged electroplated tool with tensioning capability of over 2,400 pounds, 3/4" width, and a built-in cutter. Tool is to be packed 1 each per box.

2.5 **Universal Channel Clamp.** The "saddle" shall be 16 gauge, Type 304 stainless steel, formed by tapering uniformly toward the center of larger side to a depth of 0.5 inches forming a modified "V". Locked within the saddle shall be the insert plate which shall be fabricated from 14 gauge stainless steel and form a shallow "U". See attachment No. 1 for details of clamp design. Universal channel clamps are to be packaged 50 each per box.

**3 PACKAGING**

All boxes shall be labeled with item name and quantity for each box and banded to pallets and shipped in a closed truck. All boxes are to be located and positioned so they can be unloaded from the rear of the truck with a forklift.

  
\_\_\_\_\_  
Arthur H. Breneman, P.E., Chief  
Traffic Engineering and Operations Division

(stasteba/bmm)

ATTACHMENT No. 1

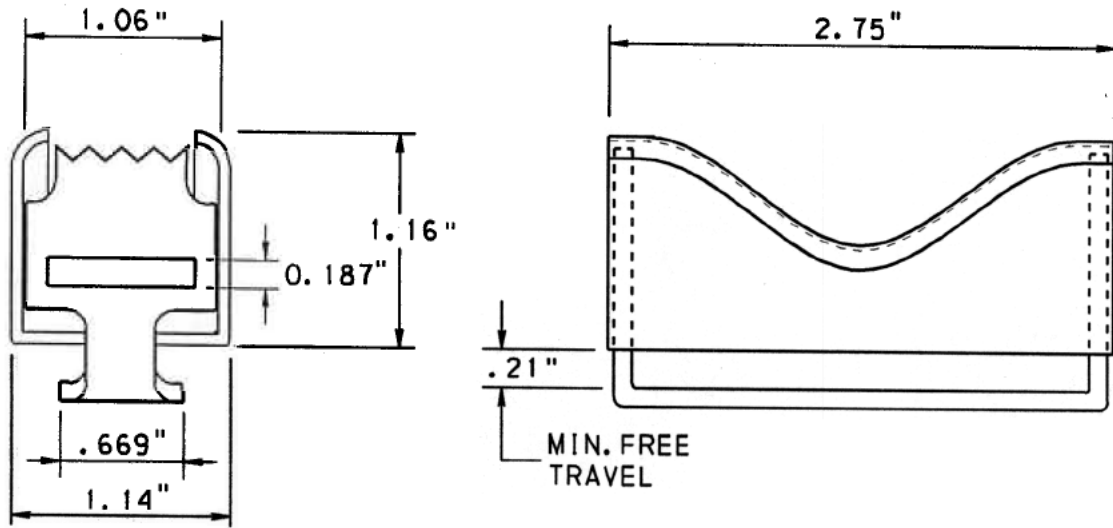

UNIVERSAL CHANNEL CLAMP